

Description

Miniaturised single pole thermal-magnetic circuit breakers with trip-free mechanism and toggle actuation (S-type TM CBE to EN 60934). Two designs provide the option of either printed circuit board or threadneck panel mounting. A separate shunt tap terminal and auxiliary contacts are available. Fast acting, medium or long delay characteristics can be specified for both models.

Suitable for use in distribution rails – see section 7.
Complies with CBE standard EN 60934 (IEC 60935).

Typical applications

Control equipment, communications systems, instrumentation.
Suitable for mounting on Euro cards.

Ordering information

Type No.	Description
2215	single pole thermal-magnetic circuit breaker
Mounting	
G1	threadneck panel mounting
L1	PCB mounting
Number of poles	
1	1-pole protected
Mounting hardware	
0	without accessories
1	2 hex nuts 1/4"-40 UNS-2A, serrated washer, location pin (-G1 only)
Terminal design (main contacts)	
P1	blade terminals 6.3-0.8, without shunt terminal
B1	blade terminals 6.3-0.8, with shunt terminal
L1	solder pins, without shunt terminal
M1	solder pins, with shunt terminal
Characteristic curve	
F1	fast acting: 1.01-1.4xI _N ; magn. 2-4xI _N DC (DC only)
M1	standard delay: therm. 1.01-1.4xI _N ; magn. 4.5-10.5xI _N DC; magn. 3.5-8xI _N AC
T1	delayed: therm. 1.01-1.4xI _N ; DC magn. 8-17xI _N DC, 6-13xI _N AC
T3	delayed: therm. 1.01-1.4xI _N ; magn. 13-20xI _N DC magn. 9.5-15.5xI _N AC
Auxiliary contacts	
S0	without auxiliary contact
S1	with auxiliary contact (change over)
Auxiliary contact - terminal design	
1	blade terminals 6.3x0.8 (QC .250)
2	solder pins
Current ratings	
0.05...10 A	
2215 - G1 1 1 - P1 F1 - S1 1 - 0.5 A ordering example	

Standard current ratings and typical internal resistance values

Current ratings (A)	Internal resistance (Ω)	Current ratings (A)	Internal resistance (Ω)
0.05	440	1.5	0.55
0.1	108	2	0.34
0.2	29.9	2.5	0.21
0.3	14.2	3	0.15
0.4	7.9	4	0.084
0.5	5.0	5	0.057
0.6	3.5	6	0.043
0.8	1.8	8	≤ 0.02
1	1.2	10	≤ 0.02

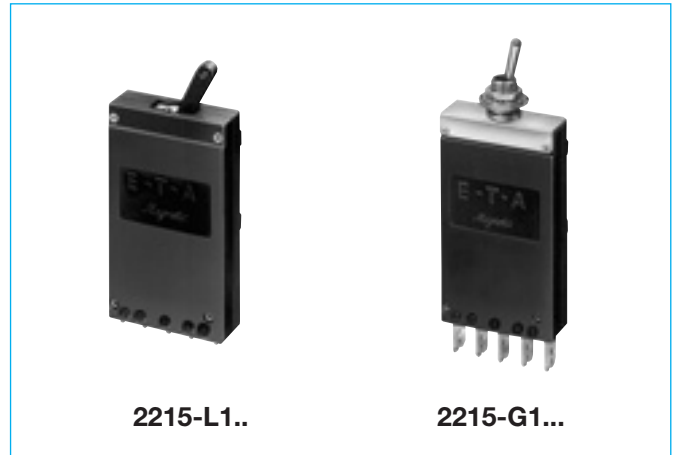

Technical data

Voltage rating	AC 250 V (50/60 Hz); DC 50 V (UL: AC 250 V; DC 75 V)		
Current rating range	0.05...10 A (higher current ratings to special order)		
Auxiliary circuit	1 A, AC 250 V/DC 28 V		
Typical life	10,000 operations at 1 x I _N		
Ambient temperature	-30...+60 °C (-22...+140 °F)		
Insulation co-ordination (IEC 60664 and 60664 A)	rated impulse withstand voltage	pollution degree	
	2.5 kV	2	
	reinforced insulation in operating area		
Dielectric strength IEC 60664 and 60664A)	test voltage	operating area	
	AC 3,000 V	AC 1,500 V	
Insulation resistance	> 100 MΩ (DC 500 V)		
Interrupting capacity I _{cn}	300 A		
Interrupting capacity (UL 1077)	I _N	U _N	
	0.05 A	AC 250 V	200 A
	0.1...6 A	AC 250 V	1,000 A
	8...10 A	AC 250 V	2,000 A
	0.05...10 A	DC 50 V	1,000 A
	0.05...10 A	DC 75 V	800 A
Degree of protection (IEC 60529/DIN 40050)	operating area IP30 terminal area IP00		
Vibration	curve F1: 6 g (57-500 Hz), ± 0.46 mm (10-57 Hz) curves M1, T1, T3: 8 g (57-500 Hz), ± 0.61 mm (10-57 Hz) to IEC 60068-2-6, test Fc 10 frequency cycles/axis		
Shock	curves F1, M1, T1, T3: 30 g (11 ms), directions 1, 2, 3, 4, 5, curve F1: 10 g (11 ms), direction 6 curves M1, T1, T3: 15 g (11 ms), direction 6 to IEC 60068-2-27, test Ea		
Corrosion	96 hours at 5 % salt mist to IEC 60068-2-11, test Ka		
Humidity	240 hours at 95 % RH to IEC 60068-2-3, test Ca		
Mass	approx. 25 g		

Approvals

Authority	Voltage ratings	Current ratings
UL	AC 250 V DC 75 V	0.05...10 A 0.05...20 A
CSA	AC 250 V; DC 48 V	0.05...10 A

Dimensions 2215-L1..

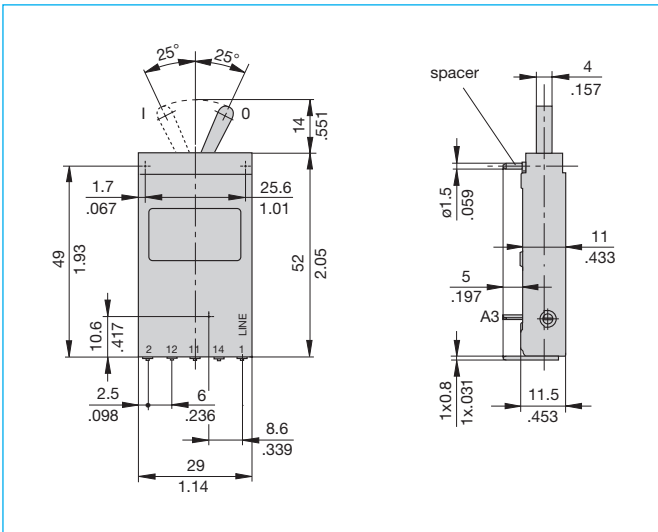

Installation drawing

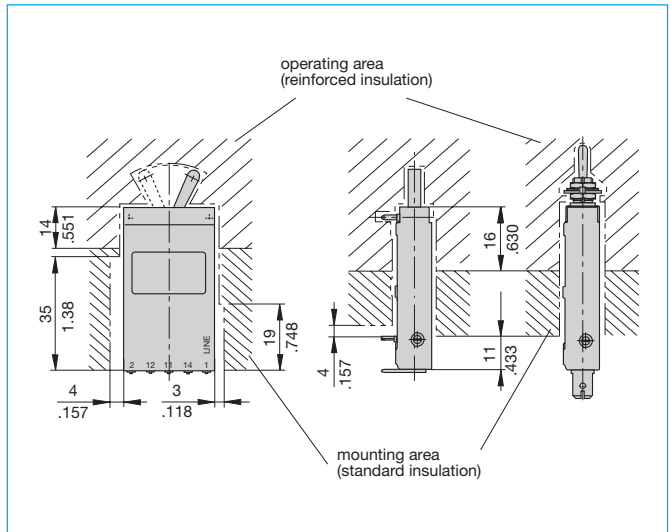

Dimensions 2215-G1..

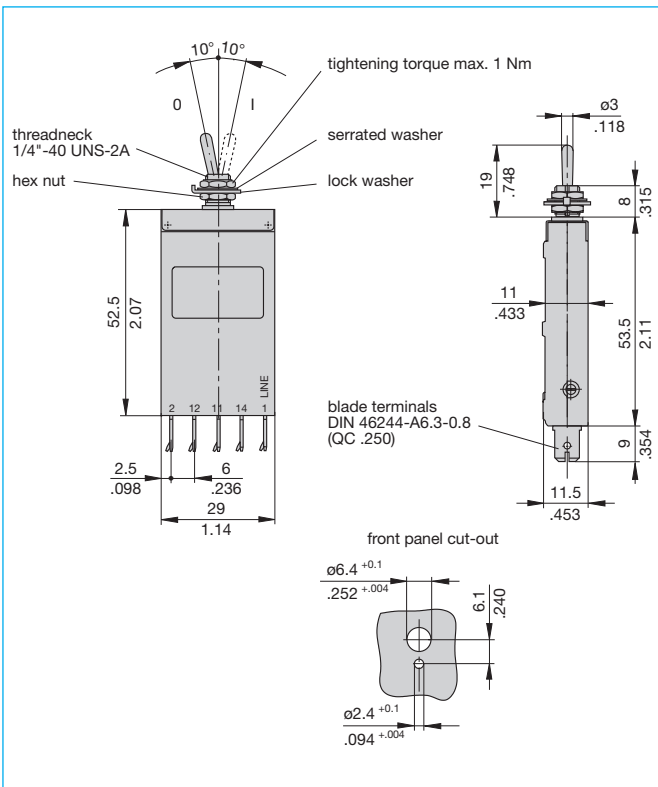

Internal connection diagram

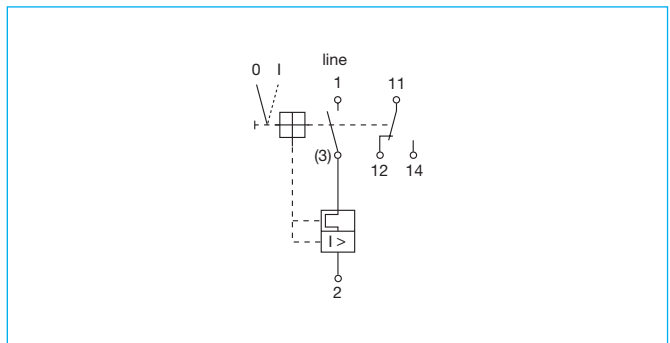

Shock directions

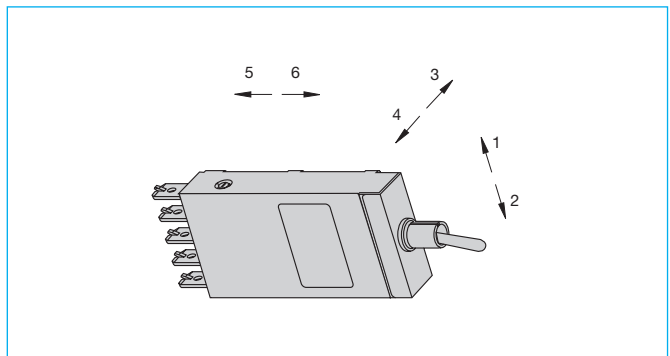

This is a metric design and millimeter dimensions take precedence ($\frac{\text{mm}}{\text{inch}}$)

Typical time/current characteristics

The time/current characteristic curve depends on the ambient temperature prevailing. In order to eliminate nuisance tripping, please multiply the circuit breaker current ratings by the derating factor shown below. See also section 9 - Technical information.

0.05...10 A:

Ambient temperature °F	-22	-4	+14	+32	+50	+73.4	+86	+104	+122	+140
°C	-30	-20	-10	0	+10	+23	+30	+40	+50	+60
Derating factor	0.76	0.79	0.83	0.88	0.93	1	1.04	1.11	1.19	1.29

-F1 0.05 6 A

DC only

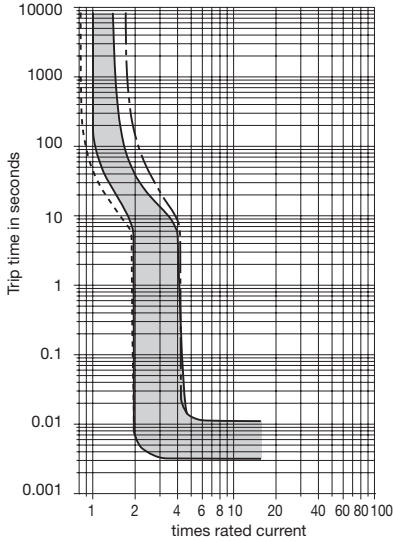

-F1 8 10 A

DC only

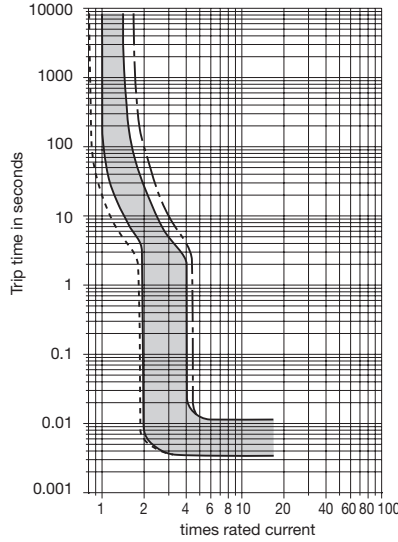

-M1 0.05 6 A

AC/DC ¹⁾

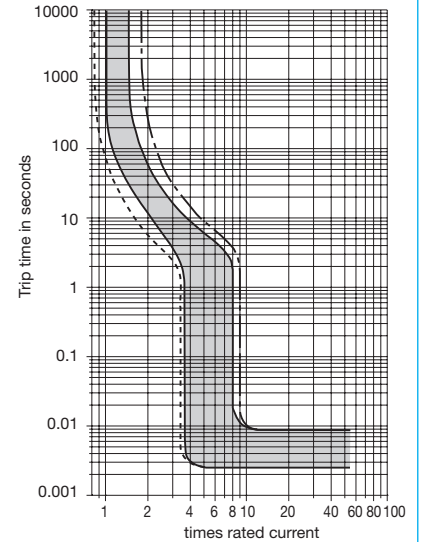

-M1 8 10 A

AC/DC ¹⁾

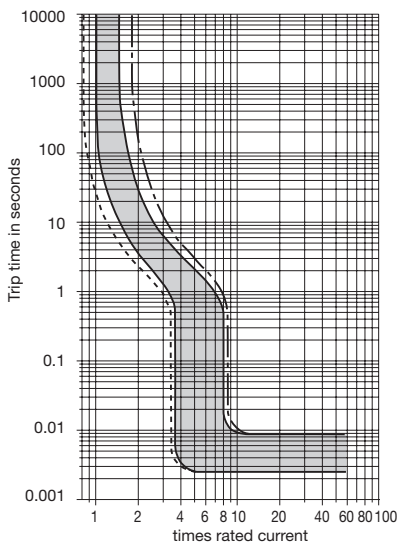

-T1 0.05 6 A

AC/DC ¹⁾

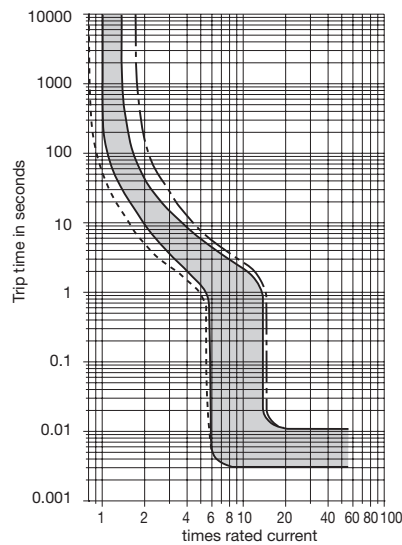

-T1 8 10 A

AC/DC ¹⁾

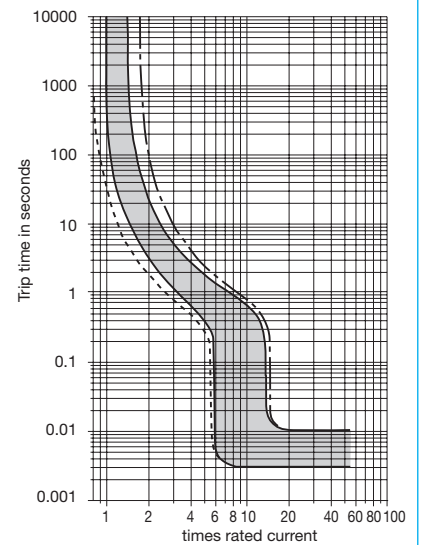

- - - - +60 °C ——— +23 °C - - - - -30 °C
 +140 °F +73.4 °F -22 °F

¹⁾ Magnetic tripping currents are increased by 30% on DC supplies (curve M1 and T1).

Typical time/current characteristics

-T3 0.05 ... 6 A

AC/DC ¹⁾

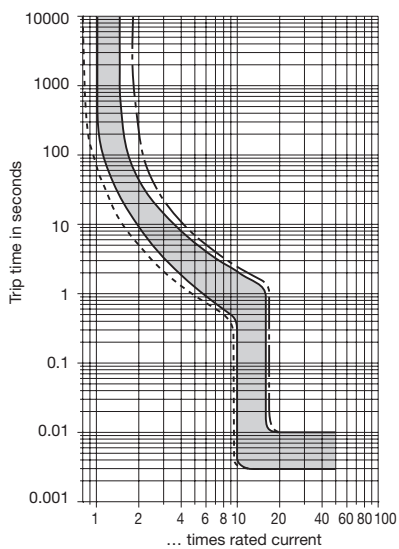

-T3 8 ... 10 A

AC/DC ¹⁾

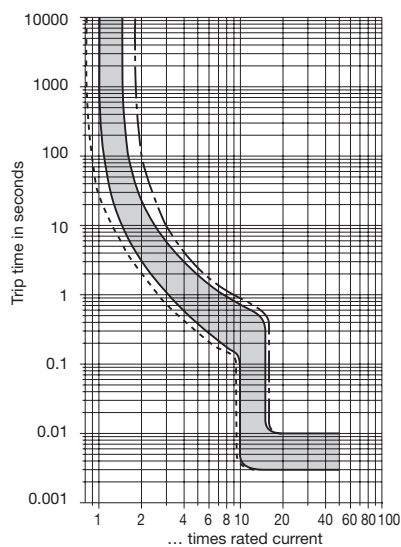

--- +60 °C
+140 °F
— +23 °C
+73.4 °F
- · - -30 °C
-22 °F

¹⁾ Magnetic tripping currents are increased by 30% on DC supplies.

All dimensions without tolerances are for reference only. In the interest of improved design, performance and cost effectiveness the right to make changes in these specifications without notice is reserved. Product markings may not be exactly as the ordering codes. Errors and omissions excepted.