

Description

The BMS01 is a battery master switch designed for dangerous goods road vehicles complying with international ADR regulations. Environmental protection and the intrinsically safe control circuitry of the BMS01 are in accordance with ADR 2011. The battery switch must be installed between the battery and the vehicle's electrical system. It is operated on and off by means of a control switch in the driver's cab, additional control switches can be sited around the vehicle as required. The BMS01 is a double pole device, but can be connected as 1-pole version (see connection diagram).

An integral safety barrier permits siting of the BMS01 in hazardous areas. Additional auxiliary contacts are provided for disconnection of the ignition circuit, de-energisation of the alternator field winding, or a controlled shutdown of the CANBUS system followed after a delay by disconnection of the battery.

Typical applications

Utility vehicles for hazardous goods.

Ordering information

Type number	
BMS01	Battery Master Switch (to ADR 2011)
Number of poles	
2	2-pole
Rated voltage	
0	DC 12 V
1	DC 24 V
Control function: delay time between auxiliary contact K13 and main contacts	
1	1 sec / ADR-compliant
2	9.5 sec / ADR-compliant
Control function: low voltage monitoring	
0	without low voltage monitoring
1	with low voltage monitoring and disconnection - device switches off in undervoltage condition
3	with low voltage monitoring and signalisation
Version	
0	neutral
BMS01 - 2 1 1 1 - 0 ordering example	

Rubber caps and mounting screws are supplied with the product. Accessories (e.g. ADR control switch, 7-pole and 4-pole connectors) should be ordered separately.

Approvals

(E1)	ECE R10 Rev. 3
(CE)	EMV directive 2004/108/EG
(ATEX)	EC directive 94/9 (for control circuit only)

Protection Class

IP65



BMS01

Technical data

Operating data

Voltage rating	DC 12 V	DC 24 V
Voltage range	9...16 V	18...32 V
Rated current	200 A / pole	
Max. overload current	2,400 A 1 s; 600 A 20 s	
Power consumption of electronic module	typically 5 mA (in OFF condition)	
Excitation current / time of the bistable main relay	12 V:	typically 2.6 A / 200 ms
	24 V:	typically 1.3 A / 200 ms

Control circuit (EX)	ZELM 04 ATEX 0213X Ex II (2) G [EEx ib] II C
Temperature range	-40...+70 °C (-40...+158 °F)
Reverse polarity protection	integral (in the event of reverse polarity the master switch will disconnect instantaneously)

Low voltage monitoring switching thresholds:	DC 12 V	DC 24 V
hysteresis:	11.0 V ± 0.3 V	22.8 V ± 0.3 V
trip time:	typically 0.25 V	typically 0.5 V
Typical life	10,000 cycles at rated current 100,000 cycles without load	

Protection class: housing	IP65
Protection class: terminals	IP54 with rubber caps
Vibration	5 g (57-200 Hz), ± 0.38 mm (10-57 Hz), test to IEC 60068-2-6, test Fc, 10 frequency cycles / axis
Shock	10 g, test to IEC 60068-2-27, test Ea
Corrosion	96 hrs 5 % salt mist, test to IEC 60068-2-11, test Ka
Humidity	240 hrs. 95 % RH, test to IEC 60068-2-3, test Cab

Terminals	battery terminals: M10 terminal studs control terminals: AUX connectors to DIN 72 585, 7-pole CRTL connectors to DIN 72 585, 2-pole
Auxiliary contact	max. 10 A (circuit unprotected)
Aux. energy output for permanently energised loads (e.g. tachograph)	max. 1 A (internally protected)
Mass	approx. 1,700 g

Signalisation by bicoloured LED

Signalisation by bicoloured LED	red and green LED
via control switch	
- Main contact closed "ON"	status LED flashes green (100 ms on; 900 ms off)
- Main contact open "OFF"	status LED flashes red (100 ms on; 900 ms off)
Low voltage detected	
- Main contact closed	status LED flashes green / red (900 ms green; 100 ms red)
- Main contact open due to low voltage	status LED red permanently on
Main contact monitoring	
- Main contact does not follow control switch "error"	status LED flashes red / green (500 ms red; 500 ms green)

Dimensions

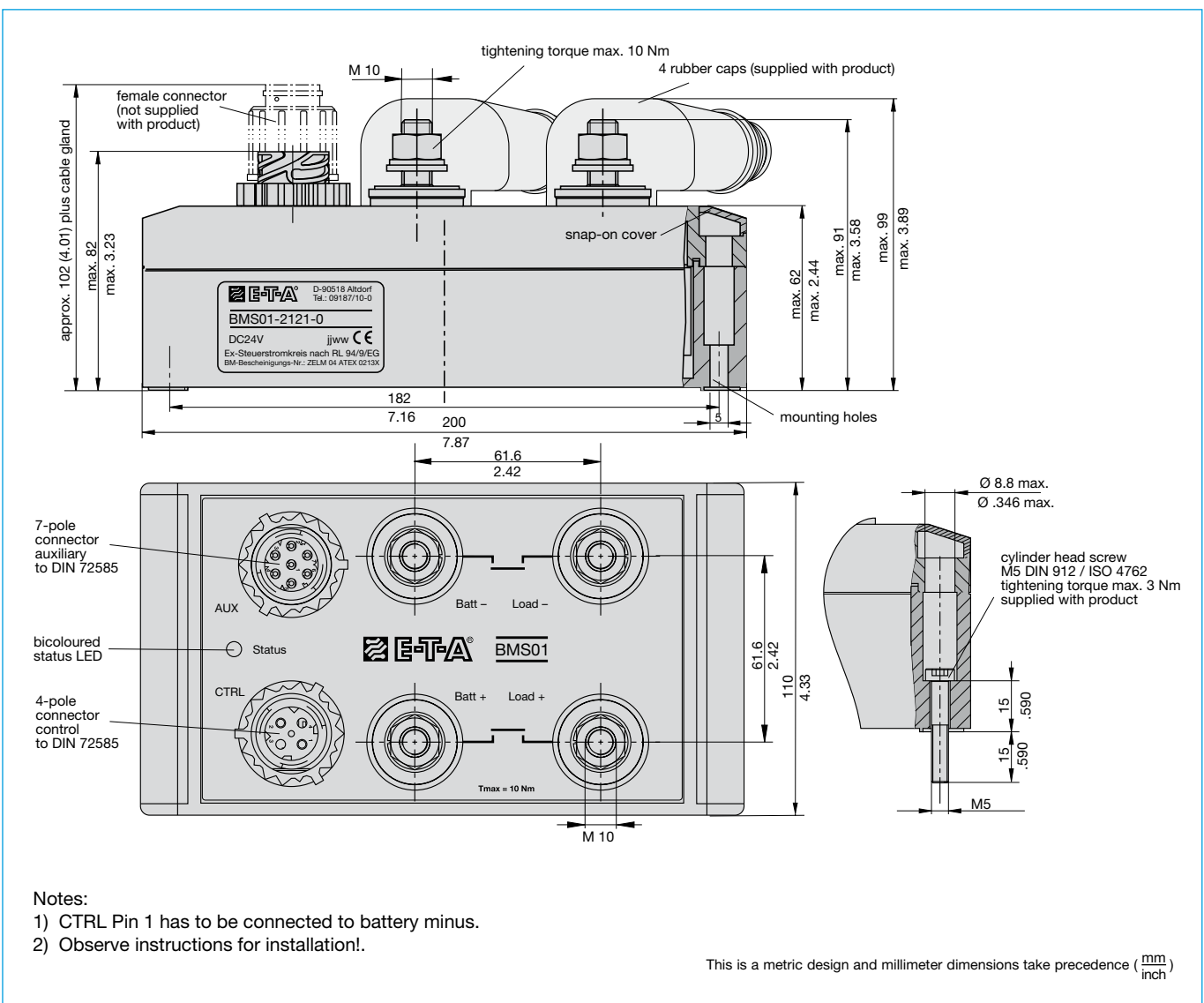

Connection diagram 1-pole

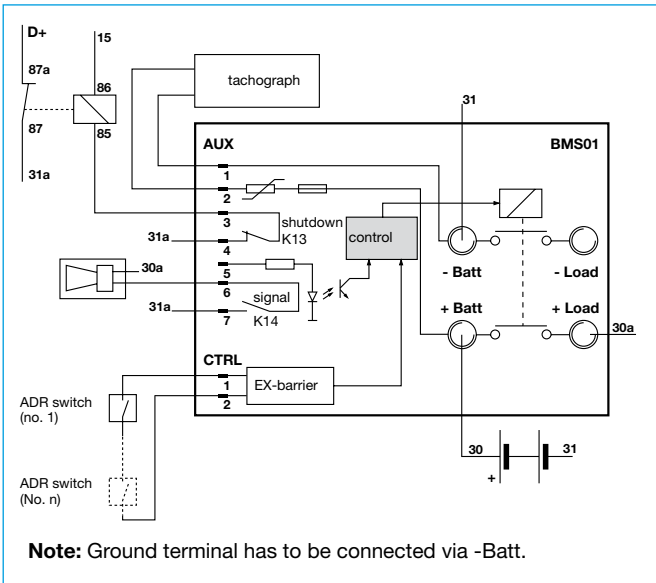

Connection diagram 2-pole

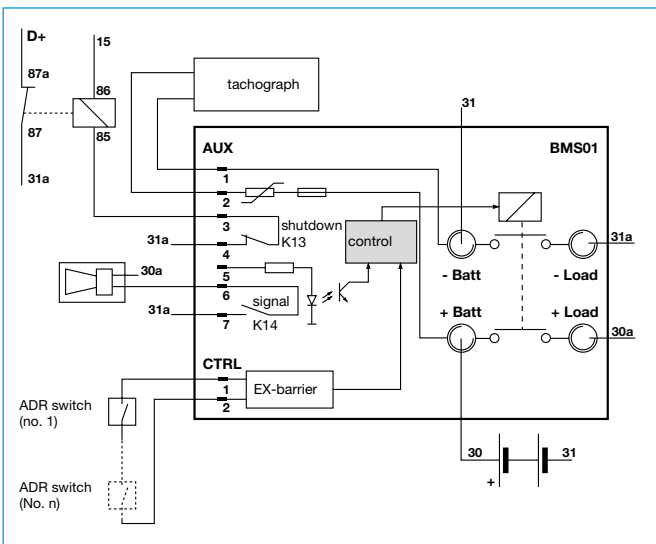

Pin Assignment

CTRL

- 1 and 2 to switch the battery isolation switch ON and OFF by means of a control switch in the driver's cab and one or more control switches outside the vehicle (if required)

AUX

- 1 and 2 current-limited supply line for permanently energised loads, e. g. tachograph, limited to 1 A
- 3 and 4 shutdown contact, which opens immediately after the control switch has been operated and remains open until the battery is disconnected
- 5 to de-activate low voltage disconnection when driving; only for configuration "1" for "Control function: low voltage monitoring"
- 6 and 7 signal contact, closes during the response delay and may be used for an acoustic alarm signal during the period until final disconnection of the battery

Terminal design

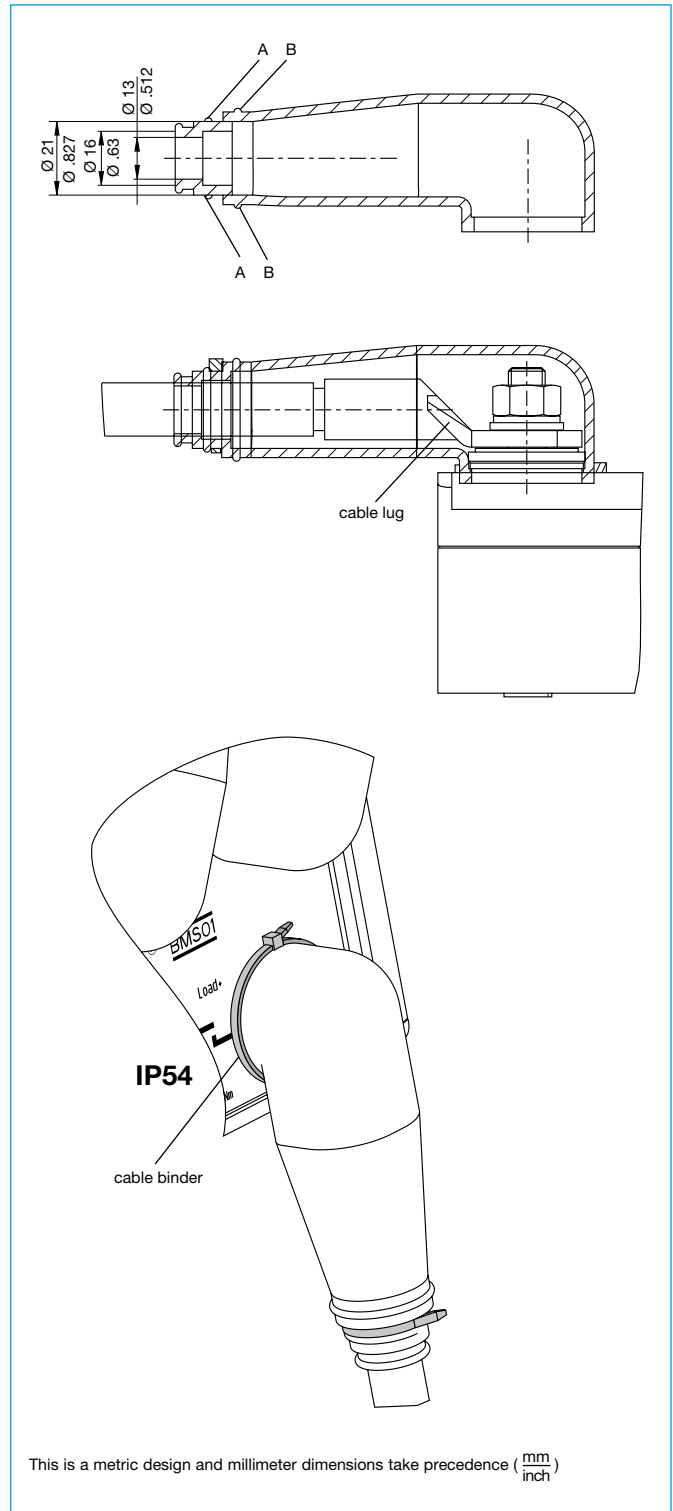

Note: the rubber caps can be cut to match the outer diameter of the connected cable.

Rubber caps

Outer cable dia. (mm)	Inner dia. of rubber caps (mm)	Cutting position
14 - 17	13	-
> 17 - 22	16	A - A
> 22 - 25.4	21	B - B

Functional diagrams

Diagram 1 Type: BMS01-1120
switch on/off via control switch

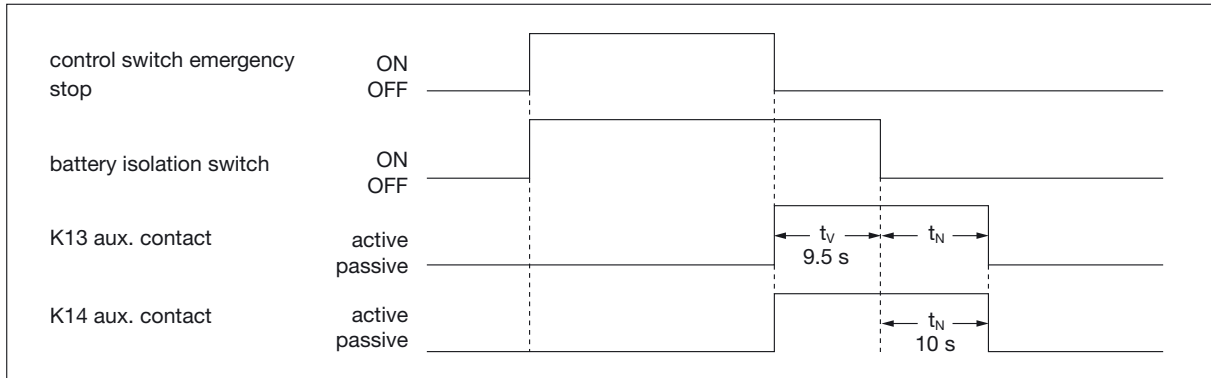

Diagram 2 Type: BMS01-1121
with low voltage monitoring and automatic disconnection

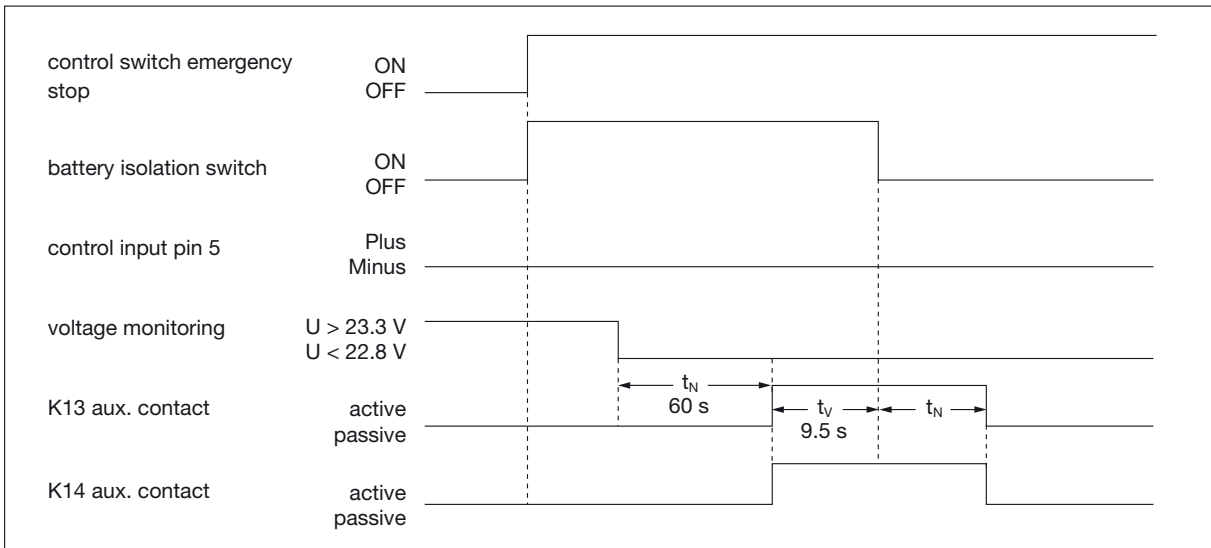
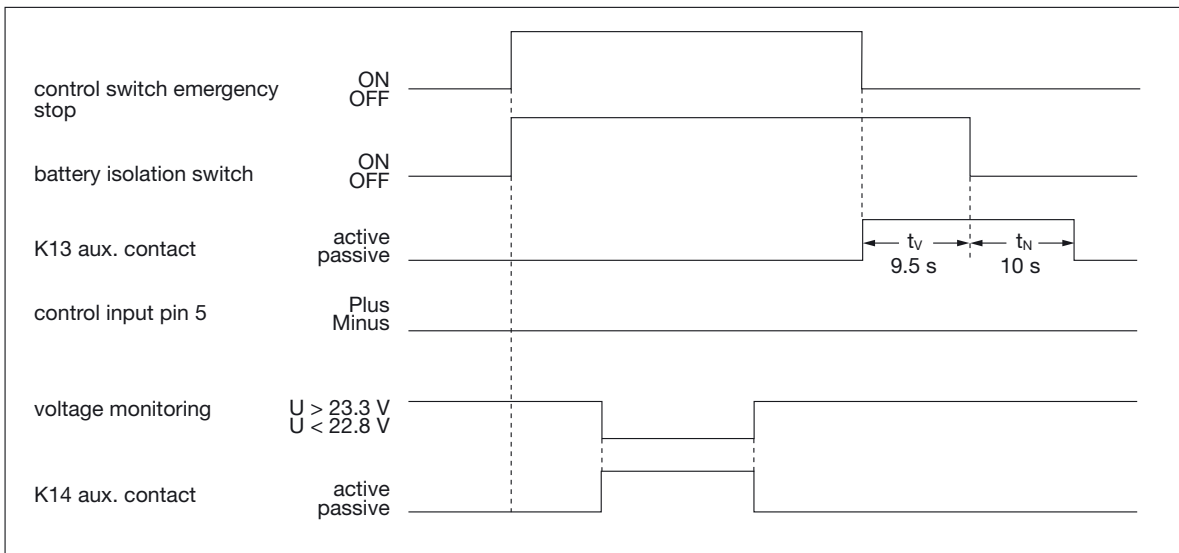
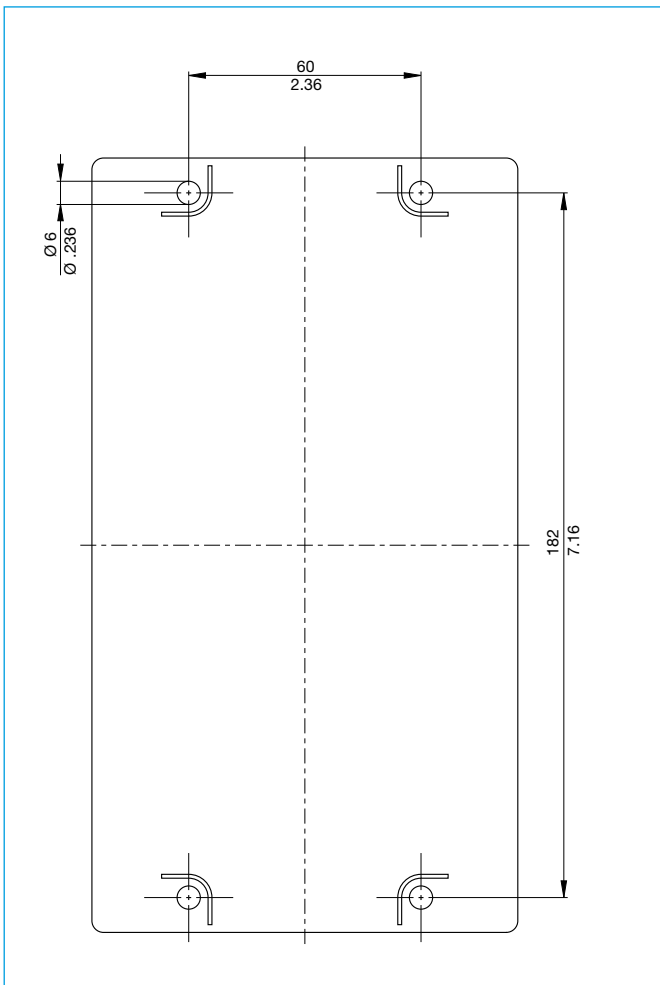

Diagram 3 Type: BMS01-1123
with low voltage monitoring and signalisation via K14 and ON/OFF operation via control switch



Mounting holes



Accessories

ADR switch with safety cover and rubber boot
(IP54 in operating area)
0Z223Z000208

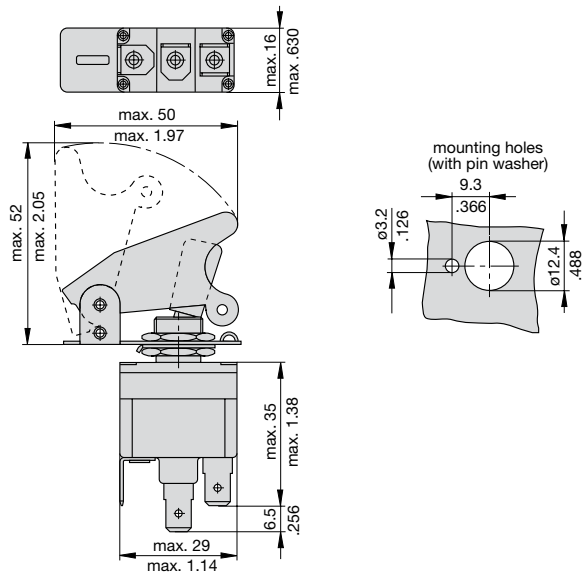

External Control Switch
XSB-A-...

XSB-B-...



For more info please enquire for a separate data sheet

Accessories

4-pole connector CTRL X 222 581 01

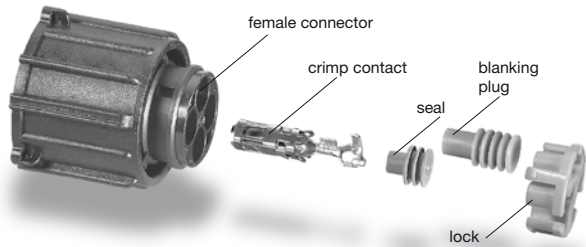

7-pole connector AUX X 222 580 01

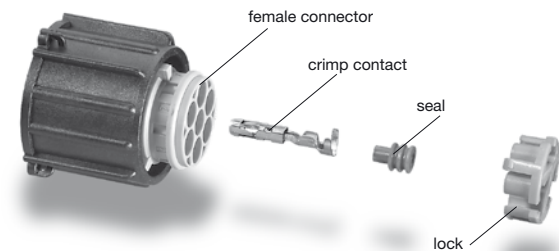

Connector sleeve (for 2- and 7-pole connectors)

Y 307 978 01 (NW10)
Y 307 979 01 (d=11 mm)

Y 307 977 01 (NW10)

