

## Description

Two pole rocker switch/thermal-magnetic circuit breaker with trip-free mechanism (S-type TM CBE to EN 60934). The addition of a magnetic tripping module to the type 3120 range described in catalogue section Thermal Overcurrent Circuit Breakers extends the choices available (thermal-magnetic protection in pole 1, thermal or no protection in pole 2). All are offered with rocker switch or push button control - two buttons for ON/OFF or one button press-to-reset only, in designs to suit one of three different panel cut-out sizes. Illumination is optional. Approved to CBE standard EN 60934 (IEC 60934).

Meets the requirements regarding fire resistance of EN 60335-1: 2007-02 Safety of household and similar electrical appliances.

## Typical applications

Motors, machine tools, office equipment, appliances.

## Standard current ratings and typical internal resistance values

Current ratings (A)	Internal resistance per pole ( $\Omega$ )	
	thermal-magnetic	thermal
0.1	165	94
0.2	42.5	24
0.3	20.2	12
0.4	9.7	5.40
0.5	7.17	4.30
0.6	4.9	3
0.8	2.65	1.50
1	1.49	0.9
1.2	1.25	0.7
1.5	0.74	0.45
2	0.49	0.29
2.5	0.20	0.0785
3	0.14	0.0595
3.5	0.114	0.0565
4	0.092	0.0435
5	0.06	0.0325
6	0.043	0.0215
7	0.030	0.0215
8	0.029	0.02
10	0.021	0.02
12	< 0.02	< 0.02
14	< 0.02	< 0.02
15	< 0.02	< 0.02
16	< 0.02	< 0.02

## Illumination voltage / Power consumption

Operating voltage	Power consumption	
	Y + R	G
230 V	0.9 mA	2.8 mA



3120-...-M...

## Technical data

For further details please see chapter: Technical Information

Voltage rating	AC 240 V (50/60 Hz); DC 50 V	
Current ratings	0.1...16 A	
Typical life	0.1...16 A 50,000 operations at 1 x I <sub>N</sub> , ind.	
Ambient temperature	-30...+60 °C (-22...+140 °F)	
Insulation co-ordination (IEC 60664 and 60664 A)	rated impulse withstand voltage	pollution degree 2
	2.5 kV reinforced insulation in operating area	
Dielectric strength (IEC 60664 and 60664A)	test voltage	
	operating area	AC 3,000 V
	current path/current path	AC 1,500 V
Insulation resistance	> 100 M $\Omega$ (DC 500 V)	
Interrupting capacity I <sub>cn</sub>	AC 0.1...2 A	100 x I <sub>N</sub>
	AC 2.5...16 A	250 A
	DC 0.1...16 A	10 x I <sub>N</sub>
Interrupting capacity (UL 1077)	I <sub>N</sub>	U <sub>N</sub>
	0.1...10 A	AC 250 V
	0.1...16 A	DC 125 V
Degree of protection (IEC 60529/DIN 40050)	operating area IP40	
	(with water splash protection IP54) terminal area IP00	
Vibration	8 g (57-500 Hz) $\pm$ 0.61 mm (10-57 Hz) to IEC 60068-2-6, test Fc 10 frequency cycles/axis	
Shock	30 g (11 ms) to IEC 60068-2-27, test Ea	
Corrosion	96 hours at 5 % salt mist to IEC 60068-2-11, test Ka	
Humidity	240 hours at 95 % RH to IEC 60068-2-78, test Cab	
Mass	approx. 53 g (2-pole)	
	approx. 50 g (1-pole)	

**Ordering information 3120 with rocker switch**

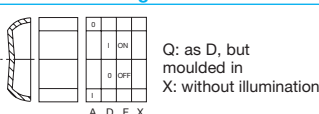
<b>Type</b>	3120 thermal-magnetic circuit breaker
<b>Mounting</b>	F snap-in frame
<b>Size of frame</b>	<p>3 Standard, to fit in cut-out 50.5 x 21.5 mm panel thickness 1 - 6.35 mm (.039-.250 in)</p> <p>5 Standard, to fit in cut-out 44.5 x 22 mm panel thickness 1 - 4 mm (.039-.157 in)</p> <p>7 Design, to fit in cut-out 45 x 33.7 mm panel thickness 1 - 4 mm (.039-.157 in)</p>
<b>Number of poles</b>	<p>2 2-pole switching and 2-pole protected (pole 1: thermal-magnetically protected, pole 2: thermally protected)</p> <p>5 2-pole switching and 1pole thermal-magnetically protected</p>
<b>Mounting frame design</b>	<p>1 collar height 1 mm (.039 in)</p> <p>3 collar height 9 mm (.354 in)</p> <p>4 collar height 2 mm (.079 in) with water splash protection (IP54)</p>
<b>Mounting frame design (F7)</b>	
<b>R</b>	black
<b>T</b>	black with snap-on splash cover
<b>Terminal configuration</b>	<p>P7 all 4 terminals 12(k), 22(k), 11, 21 blade terminals 2x2.8-0.8</p> <p>H7 12(k), 22 (k): blade terminals 2x2.8-0.8 11, 21: terminal screws M3.5, blade terminals 2x2.8-0.8</p> <p>G7 as H7, but terminals 12(i) and 22(i) are blade terminals 2x2.8-0.8 (shunt terminal)</p>
<b>Characteristic curve</b>	M1 standard delay, therm. 1.01-1.4 x I <sub>N</sub> ; magn. 4-9 x I <sub>N</sub> AC
<b>Switch style</b>	<p>W standard rocker (F3 &amp; F5)</p> <p>A specially designed rocker (F7)</p>
<b>Colour and illumination</b>	<p>01 . rocker black opaque without illumination</p> <p>02 . rocker white opaque without illumination</p> <p>04 . rocker red opaque without illumination</p> <p>14 . R rocker red translucent with LED-illumination</p> <p>15 . Y rocker orange translucent with LED-illumination</p> <p>19 . G rocker green translucent with LED-illumination</p>
<b>Rocker markings for F3 and F5</b>	 <p>Q: as D, but moulded in X: without illumination</p>
<b>Rocker markings for F7</b>	Q I« and »O« moulded in
<b>Illumination voltage range</b>	<p>1 10 - 14 V DC</p> <p>3 20 - 28 V DC</p> <p>3 90 - 140 V AC</p> <p>4 185 - 275 V AC</p>
<b>Current ratings</b>	0,1...16 A
<b>3120 -F 3 2 1 - P7 M1-W 14 A R 4 - 10 A</b> ordering example	

The exact part number required can be built up from the table of choices shown above. Ordering references for optional features should be omitted if not required.

**Ordering information 3120 with push buttons**

<b>Type</b>	3120 thermal-magnetic circuit breaker
<b>Mounting</b>	F snap-in frame
<b>Size of frame</b>	3 to fit in cut-out 50.5 x 21.5 mm panel thickness 1 - 6.35 mm
<b>Number of poles</b>	<p>2 2-pole switching and 2-pole protected (pole 1: thermal-magnetically protected, pole 2: thermally protected)</p> <p>5 2-pole switching and 1pole thermal-magnetically protected</p>
<b>Mounting frame design</b>	<p>F frame with two push buttons</p> <p>G frame with one push button</p>
<b>Terminal configuration</b>	<p>P7 all 4 terminals 12(k), 22(k), 11, 21 blade terminals 2x2.8-0.8</p> <p>H7 12(k), 22 (k): blade terminals 2x2.8-0.8 11, 21: terminal screws M3.5, blade terminals 2x2.8-0.8</p>
<b>Characteristic curve</b>	M1 standard delay, therm. 1.01-1.4 x I <sub>N</sub> ; magn. 4-9 x I <sub>N</sub> AC
<b>Actuator style / colour / illumination</b>	<p>D 01X 1 push button* black opaque without illumination</p> <p>D 02X 1 push button* white opaque without illumination</p> <p>D 04X 1 push button* red opaque without illumination</p> <p>D 19XG 1 push button* green translucent with LED-illumination</p> <p>SGRX 2 push buttons green/red opaque without illumination</p> <p>SGRXG 2 push buttons green/red translucent with LED-illumination</p>
<b>Illumination voltage range</b>	<p>1 10 - 14 V DC</p> <p>3 20 - 28 V DC</p> <p>3 90 - 140 V AC</p> <p>4 185 - 275 V AC</p>
<b>Current ratings</b>	0.1...16 A
<b>3120 -F 3 2 F - P7 M1 - SGRXG 4 - 10 A</b> ordering example	

\*Reset only  
Other push button colours upon request

**Approvals**

Authority	Voltage ratings	Current ratings
VDE (EN 60934)	AC 240 V; DC 28 V DC 50 V	0.1...16 A 0.1...16 A
CSA, UL	AC 250 V AC 125 V	0.1...10 A 0.1...16 A
CCC	AC 250 V; DC 50 V	0.1...20 A

## Dimensions

### Mounting style -F7.R

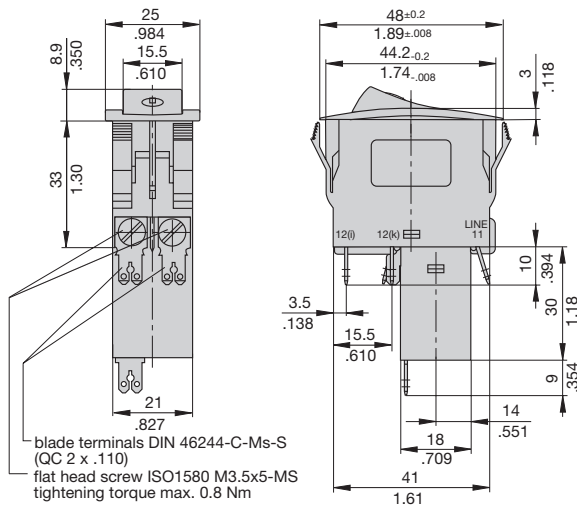

### Mounting style -F7.T

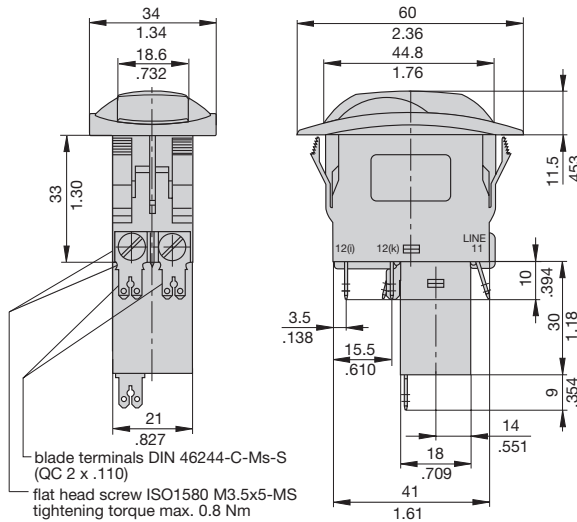

## Cut-out dimensions

### Cut-out for mounting style -F3 with rocker and push button

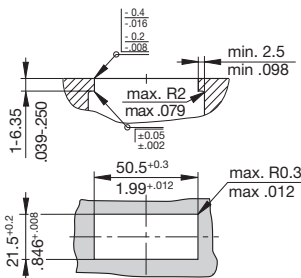

### Cut-out for mounting style -F5 with rocker

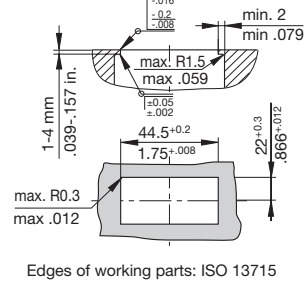

## Dimensions

### Mounting style -F3.1, with rocker – Collar height 1 mm

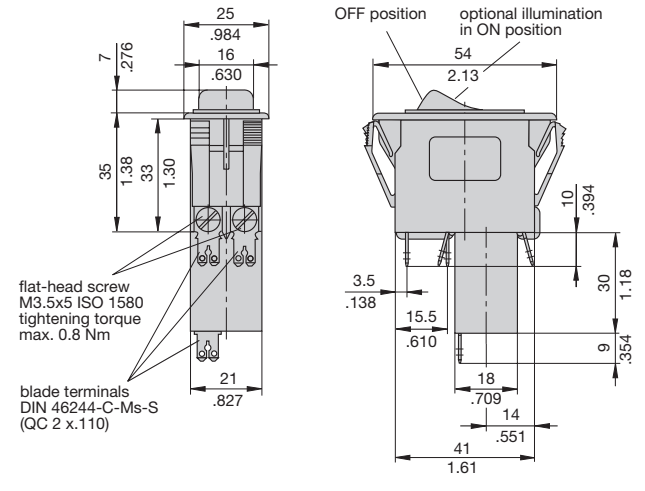

## Installation drawing

### Required safety distances for rocker and push button

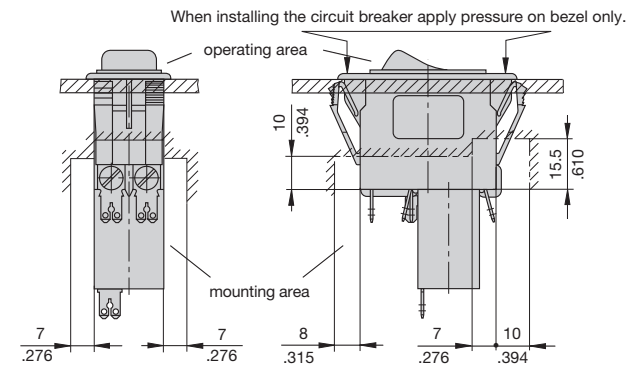

## Internal connection diagrams

### therm.-magn. protection on one pole thermally protected on the other pole

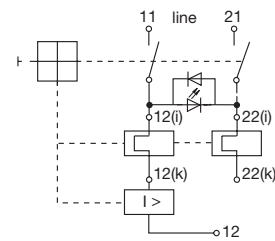

### therm.-magn. protection on one pole unprotected on the other pole

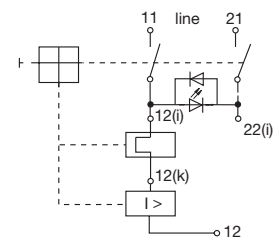

## Mounting frame variants

**Mounting style F3.3** with rocker  
collar height 9 mm (.354 in.)

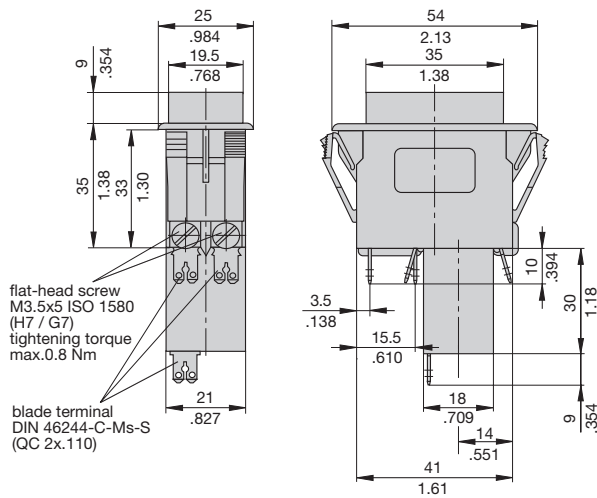

**Mounting style F3.4** with rocker  
collar height 2 mm (.079 in.), with water splash protection

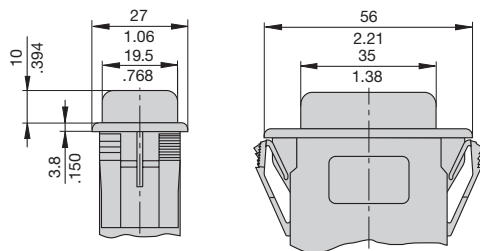

**Mounting style F3.F-...-S-...**  
with 2 push buttons

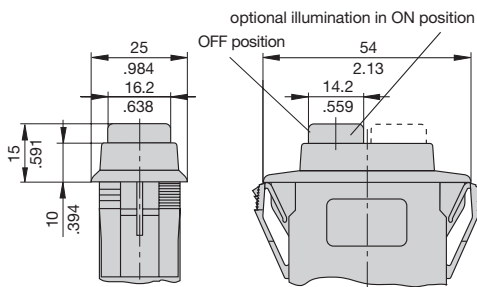

**Mounting style F3.G-...-D-...**  
with 1 push button

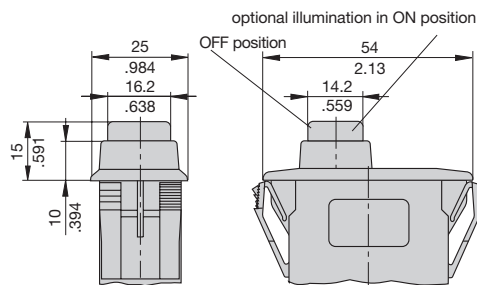

For mounting styles -F2., -F5., -F6.. please see section Thermal Overcurrent Circuit Breakers.

## Typical time/current characteristics at +23°C/+73.4°F

Single or double pole load

0.1...2 A

AC/DC <sup>1)</sup>

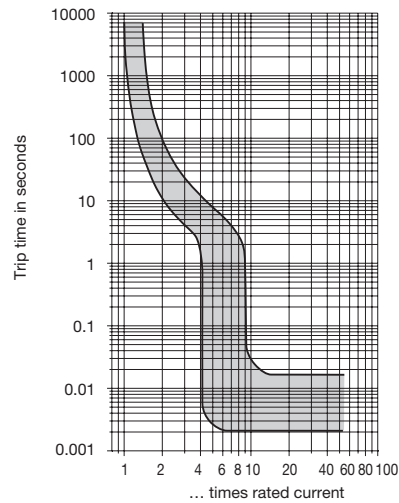

2.5...16 A

AC/DC <sup>1)</sup>

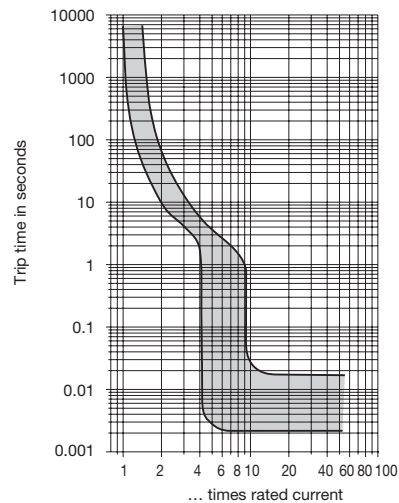

<sup>1)</sup> Magnetic tripping currents are increased by 25% on DC supplies.

The time/current characteristic curve depends on the ambient temperature prevailing. In order to eliminate nuisance tripping, please multiply the circuit breaker current ratings by the derating factor shown below. See also section Technical information.

Ambient temperature	°F	-22	-4	+14	+32	+73.4	+104	+122	+140
°C	-30	-20	-10	0	+23	+40	+50	+60	
Derating factor		0.8	0.76	0.84	0.92	1	1.08	1.16	1.24

**Accessories**

**Insulated cover  
Y 303 068 01**

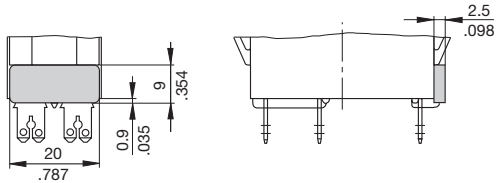

**Spacer for 3120-F3...  
Y 303 675 01/02**

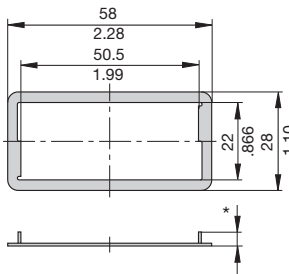

**Spacer for 3120-F5...  
Y 303 676 01**

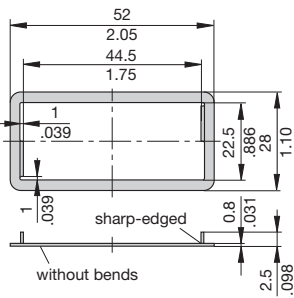

\* Y 303 675 01 suitable for panel thickness < 2 mm (.079 in)  
\* Y 303 675 02 suitable for panel thickness < 4 mm (.157 in)

**Blanking piece in -F3... size mounting frame  
Y 303 885 31**

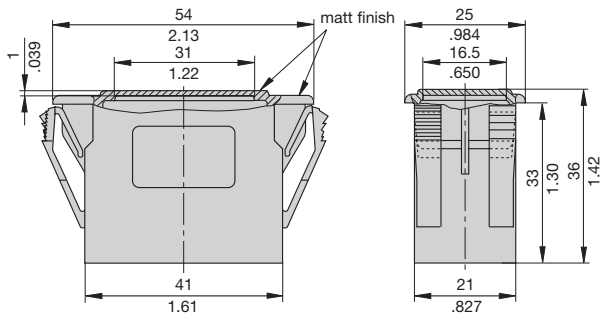

**Separate water splash cover, transparent (IP66)  
for use with -F5.. size mounting frames  
X 221 619 01**

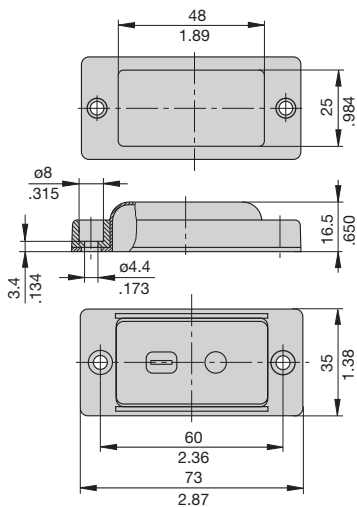

This is a metric design and millimeter dimensions take precedence ( $\frac{\text{mm}}{\text{inch}}$ )

All dimensions without tolerances are for reference only. In the interest of improved design, performance and cost effectiveness the right to make changes in these specifications without notice is reserved. Product markings may not be exactly as the ordering codes. Errors and omissions excepted.